

HIGH PERFORMANCE
PRECISION POWER TOOL SYSTEM

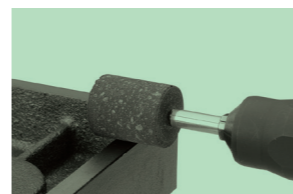

CONTENTS
DB

| | |
|---|----------|
| 研磨用ゴム砥石 Abrasive Rubber Points for Polishing | P127-132 |
| 研削用ゴム砥石 Abrasive Rubber Points for Grinding | P133-138 |
| 弾性砥石について Explanation for Elastic Points | P147-150 |

軸付ゴム砥石
Abrasive Rubber Points



研磨用ゴム砥石

Abrasive Rubber Points for Polishing

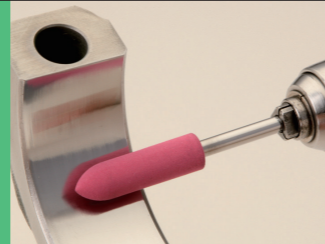

特徴 Features

- 研磨作業に適したゴム砥石です。
Suitable for polishing.
- 優れた自生作用により、細目粒度であっても目づまりが起こりません。
By excellent autogenous actions, clogging is hardly caused even though tools have impalpable grain size in case of polishing non-ferrous metals.

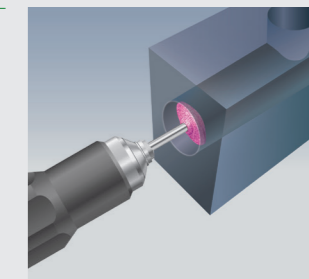

| | | | | | | | |
|---------------------------------|--------------------------------|---|--------------------------------|---------------------------------|---------------------------|--|-----------------------------------|
| 適合素材 Applicable Materials | セラミックス・ガラス Ceramics / Glass | 工具鋼・合金鋼 Tool Steel / Alloy Steel | 樹脂・ゴム Resin / Rubber | 適合機器類 Applicable Machines | エアグラインダー Air Grinder | ボール盤・電気ドリル Drill Press / Electric Drill | スピンドル Machine Tools Attachment |
| | 超硬合金・サーメット Carbide / Cermet | 一般鋼・ステンレス General Steels / Stainless Steel | アルミニウム・銅 Aluminium / Copper | | 両頭グラインダー Bench Grinder | ハンド Hand Use | 自動機ロボット Automatic Machines |

MINIMO推奨ハンドピース Recommended MINIMO Handpieces ●最適 Most Suitable ●使用可能 Suitable

- V112H V212H M112H M212H V212 M112 M212 M212L M112G V112 HS V212 HS M112 HS M112S M212 HD M212D M212 RA M212 RAD M212A M112 GRA M112 GRAD M112 GA RE112 RE212 M212 LRV BS312 US21

1 Pack
10 Pieces
Shank ϕ 2.34

30,000 r.p.m. 20,000 r.p.m. 30,000 r.p.m. 30,000 r.p.m. 15,000 r.p.m. 30,000 r.p.m.

| | | | | |
|-------|---------|---------|---------|---------|
| #120 | DB 1101 | DB 1111 | DB 1161 | DB 1181 |
| #280 | DB 1102 | DB 1112 | | DB 1182 |
| #400 | DB 1103 | | | DB 1183 |
| #1800 | DB 1104 | DB 1113 | DB 1162 | DB 1184 |
| | | | DB 1171 | DB 1192 |

1 Pack
10 Pieces
Shank ϕ 2.34

25,000 r.p.m. 20,000 r.p.m. 15,000 r.p.m. 25,000 r.p.m. 15,000 r.p.m.

| | | | | | |
|-------|---------|---------|---------|---------|---------|
| #120 | | | | DB 1411 | DB 1421 |
| #180 | DB 1331 | | | DB 1412 | DB 1422 |
| #220 | DB 1332 | DB 1341 | DB 1351 | DB 1413 | DB 1423 |
| #320 | DB 1333 | DB 1342 | DB 1352 | DB 1414 | DB 1424 |
| #600 | DB 1334 | DB 1343 | DB 1353 | DB 1415 | DB 1425 |
| #1000 | DB 1335 | | | DB 1416 | |
| #2000 | | | | DB 1417 | |

1 Pack
10 Pieces
Shank ϕ 2.34

20,000 r.p.m.

| | | | | |
|-------|---------|---------|---------|---------|
| #120 | | DB 1221 | DB 1241 | DB 1251 |
| #220 | DB 1211 | DB 1222 | DB 1242 | DB 1252 |
| #320 | | DB 1223 | DB 1243 | DB 1253 |
| #600 | | DB 1224 | | |
| #800 | DB 1212 | | | |
| #1000 | | DB 1225 | | |
| #1200 | DB 1213 | | | |

30,000 r.p.m.

| | | | |
|------|---------|---------|---------|
| #180 | DB 1501 | | |
| #220 | | DB 1561 | DB 1571 |
| #320 | DB 1502 | DB 1562 | DB 1572 |
| #600 | DB 1503 | | |

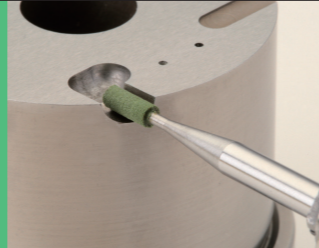

特徴 Features

- 研磨作業に適したゴム砥石です。
Suitable for polishing.
- 優れた自生作用により、細目粒度であっても目づまりが起こりません。
By excellent autogenous actions, clogging is hardly caused even though tools have impalpable grain size in case of polishing non-ferrous metals.

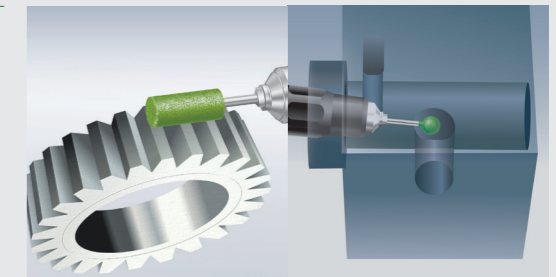

| | | | | | | | |
|------------------------------|--------------------------------|---|--------------------------------|------------------------------|---------------------------|--|-----------------------------------|
| 適合素材 Applicable Materials | セラミックス・ガラス Ceramics / Glass | 工具鋼・合金鋼 Tool Steel / Alloy Steel | 樹脂・ゴム Resin / Rubber | 適合機器類 Applicable Machines | エアグラインダー Air Grinder | ボール盤・電気ドリル Drill Press / Electric Drill | スピンドル Machine Tools Attachment |
| | 超硬合金・サーメット Carbide / Cermet | 一般鋼・ステンレス General Steels / Stainless Steel | アルミニウム・銅 Aluminium / Copper | | 両頭グラインダー Bench Grinder | ハンド Hand Use | 自動機ロボット Automatic Machines |

MINIMO推奨ハンドピース Recommended MINIMO Handpieces ●最適 Most Suitable ●使用可能 Suitable

- V112H V212H M112H M212H V212 M112 M212 M212L M112G V112 HS V212 HS M112 HS M112S M212 HD M212D M212 RA M212 RAD M212A M112 GRA M112 GRAD M112 GA RE112 RE212 M212 LRV BS312 US21

1 Pack
10 Pieces Shank ϕ 3.0

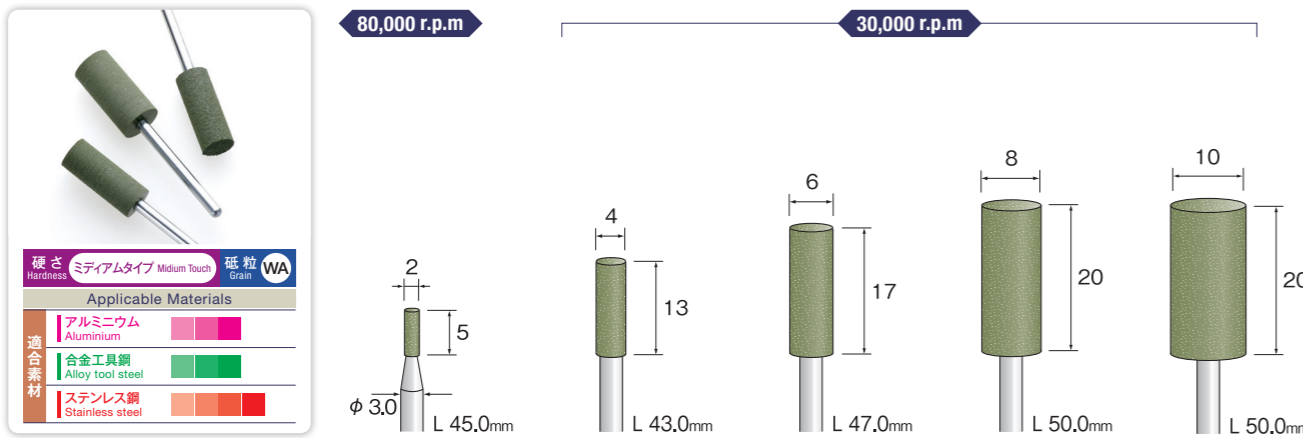

| | | | | | |
|------|---------|---------|---------|---------|---------|
| #220 | DB 3001 | DB 3011 | DB 3021 | DB 3031 | DB 3041 |
| #320 | DB 3002 | DB 3012 | DB 3022 | DB 3032 | DB 3042 |
| #400 | DB 3003 | DB 3013 | DB 3023 | DB 3033 | DB 3043 |

1 Pack
10 Pieces Shank ϕ 3.0

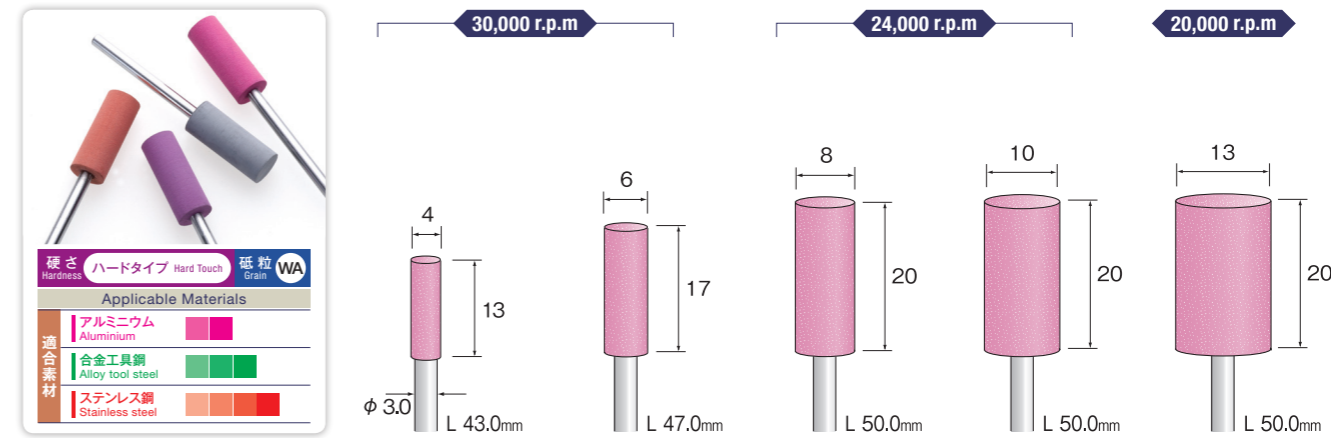

| | | | | | |
|-------|---------|---------|---------|---------|---------|
| #220 | DB 3201 | DB 3211 | DB 3221 | DB 3231 | DB 3241 |
| #320 | DB 3202 | DB 3212 | DB 3222 | DB 3232 | DB 3242 |
| #600 | DB 3203 | DB 3213 | DB 3223 | DB 3233 | DB 3243 |
| #1000 | DB 3204 | DB 3214 | DB 3224 | DB 3234 | DB 3244 |

1 Pack
10 Pieces Shank ϕ 3.0

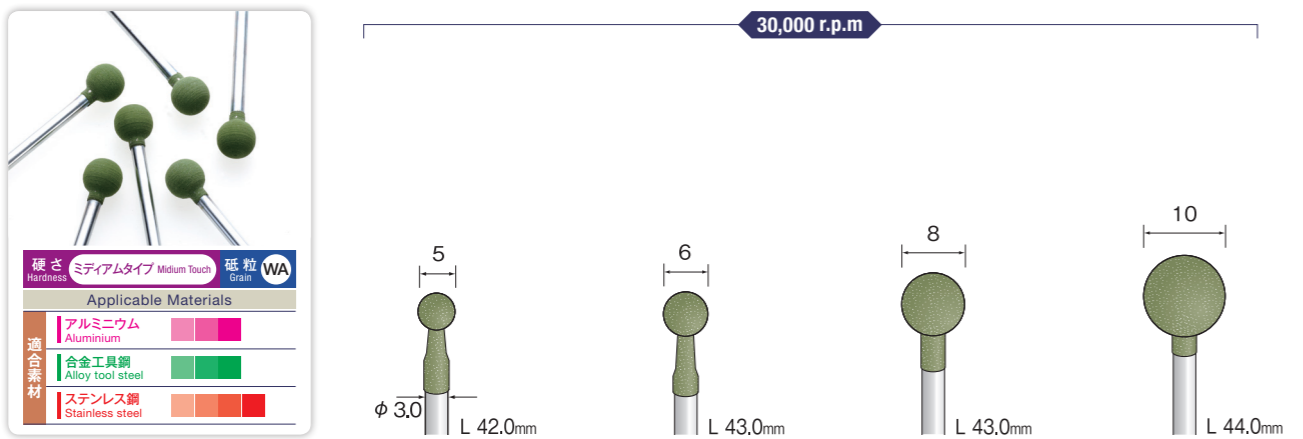

| | | | | |
|------|---------|---------|---------|---------|
| #80 | DB 3101 | DB 3111 | DB 3121 | DB 3131 |
| #120 | DB 3102 | DB 3112 | DB 3122 | DB 3132 |
| #180 | DB 3103 | DB 3113 | DB 3123 | DB 3133 |
| #220 | DB 3104 | DB 3114 | DB 3124 | DB 3134 |
| #320 | DB 3105 | DB 3115 | DB 3125 | DB 3135 |
| #400 | DB 3106 | DB 3116 | DB 3126 | DB 3136 |

1 Pack
10 Pieces Shank ϕ 3.0

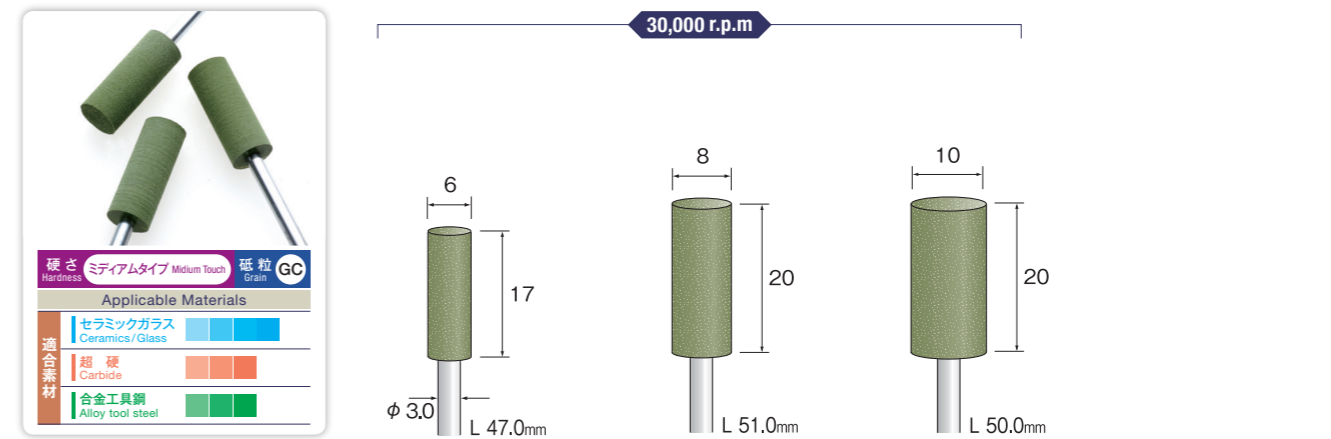

| | | | |
|------|---------|---------|---------|
| #120 | DB 3511 | DB 3521 | DB 3531 |
| #220 | DB 3512 | DB 3522 | DB 3532 |
| #320 | DB 3513 | DB 3523 | DB 3533 |

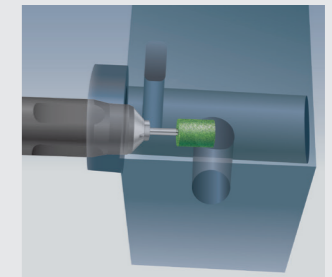

特徴 Features

- 研磨作業に適したゴム砥石です。
Suitable for polishing.
- 優れた自生作用により、細目粒度であっても目づまりが起こりません。
By excellent autogenous actions, clogging is hardly caused even though tools have impalpable grain size in case of polishing non-ferrous metals.

| | | | | | | | |
|------------------------------|--------------------------------|---|--------------------------------|------------------------------|---------------------------|--|-----------------------------------|
| 適合素材 Applicable Materials | セラミックス・ガラス Ceramics / Glass | 工具鋼・合金鋼 Tool Steel / Alloy Steel | 樹脂・ゴム Resin / Rubber | 適合機器類 Applicable Machines | エアグラインダー Air Grinder | ボール盤・電気ドリル Drill Press / Electric Drill | スピンドル Machine Tools Attachment |
| | 超硬合金・サーメット Carbide / Cermet | 一般鋼・ステンレス General Steels / Stainless Steel | アルミニウム・銅 Aluminium / Copper | | 両頭グラインダー Bench Grinder | ハンド Hand Use | 自動機ロボット Automatic Machines |

MINIMO推奨ハンドピース Recommended MINIMO Handpieces ●最適 Most Suitable ●使用可能 Suitable

| | | | | | | | | | | | | | | | | | | | | | | | | | |
|-------|-------|-------|-------|------|------|------|-------|-------|---------|---------|---------|-------|---------|-------|---------|----------|-------|----------|-----------|---------|-------|-------|----------|-------|------|
| V112H | V212H | M112H | M212H | V212 | M112 | M212 | M212L | M112G | V112 HS | V212 HS | M112 HS | M112S | M212 HD | M212D | M212 RA | M212 RAD | M212A | M112 GRA | M112 GRAD | M112 GA | RE112 | RE212 | M212 LRV | BS312 | US21 |
|-------|-------|-------|-------|------|------|------|-------|-------|---------|---------|---------|-------|---------|-------|---------|----------|-------|----------|-----------|---------|-------|-------|----------|-------|------|

1Pack
5 Pieces Shank ϕ 6.0

硬さ ミディアムタイプ Medium Touch 砥粒 WA

Applicable Materials

アルミニウム
Aluminium

合金工具鋼
Alloy tool steel

ステンレス鋼
Stainless steel

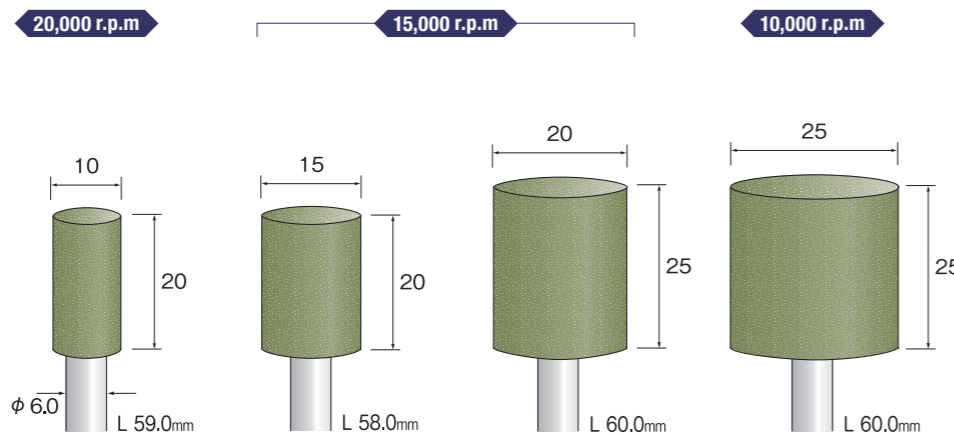

| | | | | |
|------|---------|---------|---------|---------|
| #120 | DB 4101 | DB 4111 | DB 4121 | DB 4131 |
| #220 | DB 4102 | DB 4112 | DB 4122 | DB 4132 |
| #320 | DB 4103 | DB 4113 | DB 4123 | DB 4133 |
| #400 | DB 4104 | DB 4114 | DB 4124 | DB 4134 |

1Pack
5 Pieces Shank ϕ 6.0

硬さ ミディアムタイプ Medium Touch 砥粒 GC

Applicable Materials

セラミックガラス
Ceramics / Glass

超硬
Carbide

合金工具鋼
Alloy tool steel

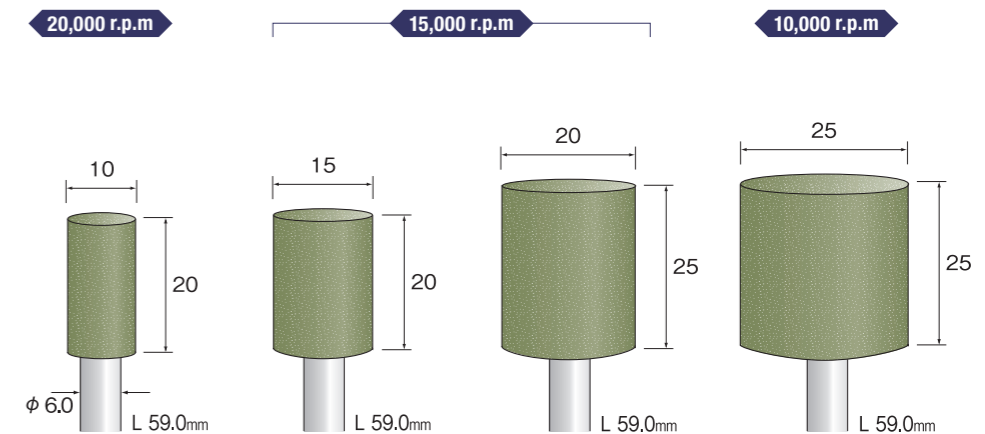

| | | | | |
|------|---------|---------|---------|---------|
| #120 | DB 4301 | DB 4311 | DB 4321 | DB 4331 |
| #220 | DB 4302 | DB 4312 | DB 4322 | DB 4332 |
| #320 | DB 4303 | DB 4313 | DB 4323 | DB 4333 |

1Pack
5 Pieces Shank ϕ 6.0

硬さ ハードタイプ Hard Touch 砥粒 WA

Applicable Materials

アルミニウム
Aluminium

合金工具鋼
Alloy tool steel

ステンレス鋼
Stainless steel

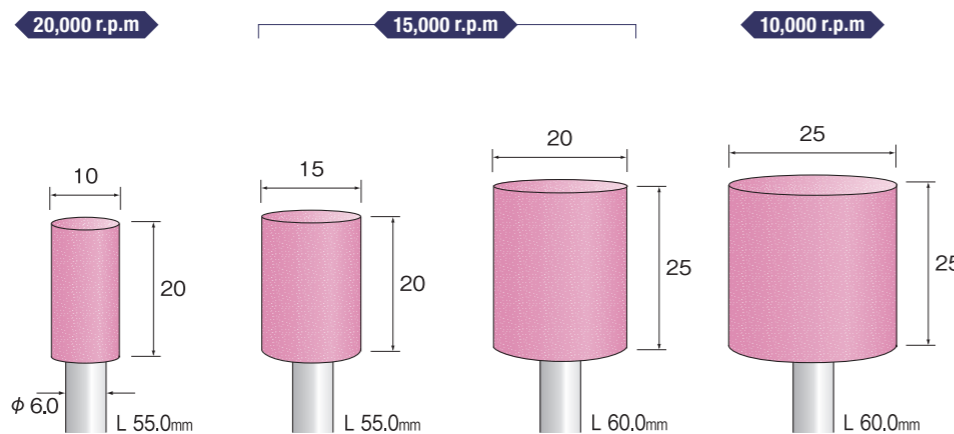

| | | | | |
|------|---------|---------|---------|---------|
| #120 | DB 4201 | DB 4211 | DB 4221 | DB 4231 |
| #220 | DB 4202 | DB 4212 | DB 4222 | DB 4232 |
| #320 | DB 4203 | DB 4213 | DB 4223 | DB 4233 |
| #600 | DB 4204 | DB 4214 | DB 4224 | DB 4234 |



| | | | | | | | | |
|-------------------------------|--|--------------------------------|---|--------------------------------|--|---------------------------|--|-----------------------------------|
| AD ダイヤモンド/ CBN工具 | 適合素材 Applicable Materials | セラミックス・ガラス Ceramics / Glass | 工具鋼・合金鋼 Tool Steel / Alloy Steel | 樹脂・ゴム Resin / Rubber | 適合機器類 Applicable Machines | エアグラインダー Air Grinder | ボール盤・電気ドリル Drill Press / Electric Drill | スピンドル Machine Tools Attachment |
| BC 超硬 カッター | | 超硬合金・サーメット Carbide / Cermet | 一般鋼・ステンレス General Steels / Stainless Steel | アルミニウム・銅 Aluminium / Copper | | 両頭グラインダー Bench Grinder | ハンド Hand Use | 自動機ロボット Automatic Machines |

MINIMO推奨ハンドピース Recommended MINIMO Handpieces

●最適 Most Suitable ●使用可能 Suitable

- V112H V212H M112H M212H V212 M112 M212 V112L M112G V112 HS V212 HS M112 HS M112S M212 HD M212D M212 RA M212 RAD M212A M112 GRA M112 GRAD M112 GA RE112 RE212 M212 LRV BS312 US21

1 Pack
10 Pieces
Shank ϕ 3.0

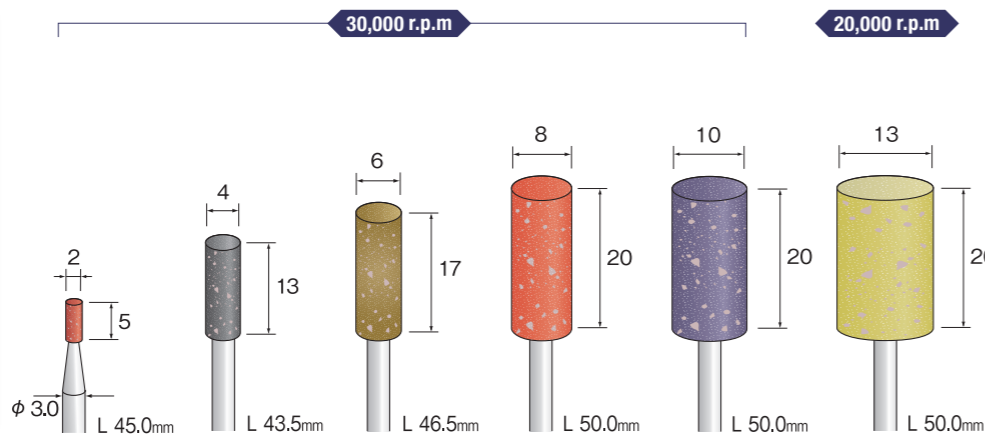

| | | | | | | |
|------|---------|---------|---------|---------|---------|---------|
| #80 | DB 2011 | DB 2021 | DB 2031 | DB 2041 | DB 2051 | DB 2061 |
| #120 | DB 2012 | DB 2022 | DB 2032 | DB 2042 | DB 2052 | DB 2062 |
| #180 | DB 2013 | DB 2023 | DB 2033 | DB 2043 | DB 2053 | DB 2063 |
| #220 | DB 2014 | DB 2024 | DB 2034 | DB 2044 | DB 2054 | DB 2064 |
| #320 | DB 2015 | DB 2025 | DB 2035 | DB 2045 | DB 2055 | DB 2065 |
| #400 | | DB 2026 | DB 2036 | DB 2046 | DB 2056 | DB 2066 |

1 Pack
10 Pieces
Shank ϕ 3.0

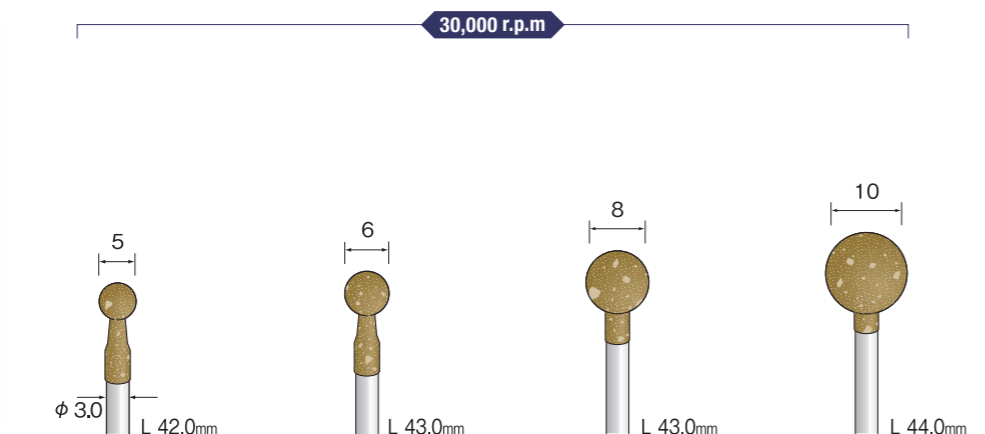

| | | | | |
|------|---------|---------|---------|---------|
| #80 | DB 2101 | DB 2111 | DB 2121 | DB 2131 |
| #120 | DB 2102 | DB 2112 | DB 2122 | DB 2132 |
| #180 | DB 2103 | DB 2113 | DB 2123 | DB 2133 |
| #220 | DB 2104 | DB 2114 | DB 2124 | DB 2134 |
| #320 | DB 2105 | DB 2115 | DB 2125 | DB 2135 |
| #400 | DB 2106 | DB 2116 | DB 2126 | DB 2136 |

特徴 Features

- 研削作業に適したゴム砥石です。
Suitable for grinding.
- 弾性効果により、スクラッチが入りにくく、均一な研削面が得られます。
Providing uniform finishing without much scratching by elastic effect.

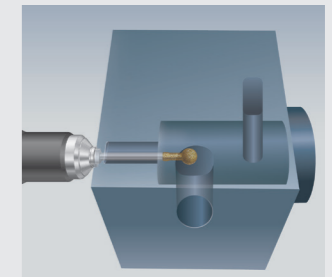

1 Pack
10 Pieces
Shank ϕ 3.0

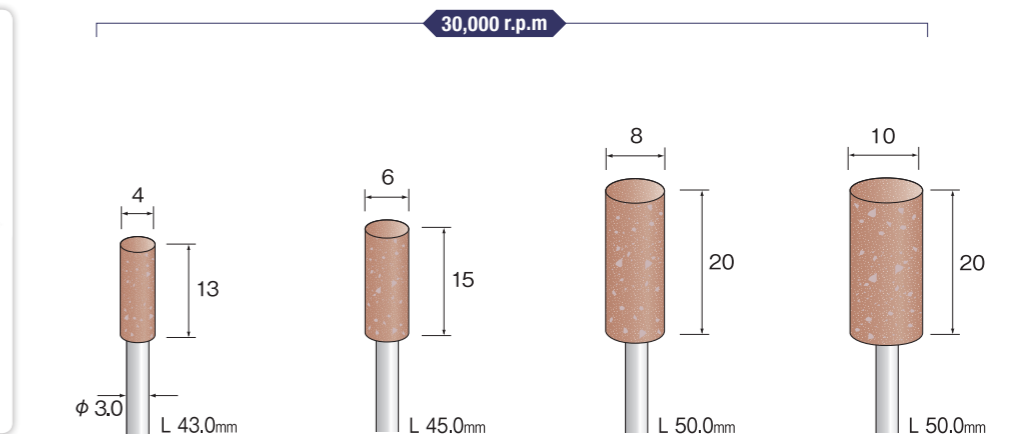

| | | | | |
|------|---------|---------|---------|---------|
| #80 | DB 2201 | DB 2221 | DB 2231 | DB 2241 |
| #120 | DB 2202 | DB 2222 | DB 2232 | DB 2242 |
| #220 | DB 2203 | DB 2223 | DB 2233 | DB 2243 |

1 Pack
10 Pieces
Shank ϕ 3.0

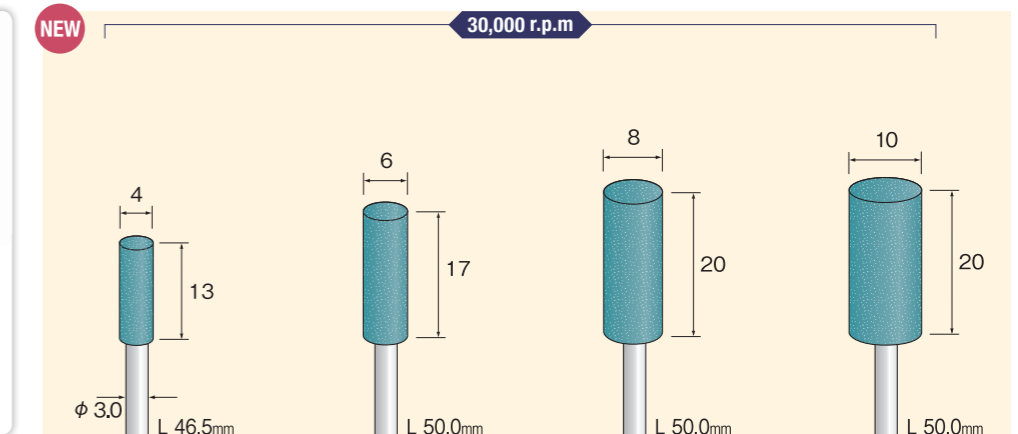

| | | | | |
|------|---------|---------|---------|---------|
| #80 | DB 2401 | DB 2411 | DB 2421 | DB 2431 |
| #120 | DB 2402 | DB 2412 | DB 2422 | DB 2432 |
| #220 | DB 2403 | DB 2413 | DB 2423 | DB 2433 |
| #320 | DB 2404 | DB 2414 | DB 2424 | DB 2434 |
| #600 | DB 2405 | DB 2415 | DB 2425 | DB 2435 |
| #800 | DB 2406 | DB 2416 | DB 2426 | DB 2436 |

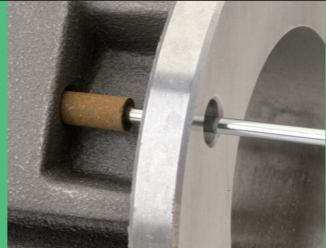

特徴 Features

- 研削作業に適したゴム砥石です。
Suitable for grinding.
- 深穴、深いスリット等の研削加工に最適です。
Suitable for grinding in deep hole and slit.

| | | | | | | | |
|---------------------------------|--------------------------------|---|--------------------------------|---------------------------------|---------------------------|--|-----------------------------------|
| 適合素材 Applicable Materials | セラミックス・ガラス Ceramics / Glass | 工具鋼・合金鋼 Tool Steel / Alloy Steel | 樹脂・ゴム Resin / Rubber | 適合機器類 Applicable Machines | エアークラインダー Air Grinder | ボール盤・電気ドリル Drill Press / Electric Drill | スピンドル Machine Tools Attachment |
| | 超硬合金・サーメット Carbide / Cermet | 一般鋼・ステンレス General Steels / Stainless Steel | アルミニウム・銅 Aluminium / Copper | | 両頭グラインダー Bench Grinder | ハンド Hand Use | 自動機ロボット Automatic Machines |

MINIMO推奨ハンドピース Recommended MINIMO Handpieces ●最適 Most Suitable ●使用可能 Suitable

- V112H V212H M112H M212H V212 M112 M212 M212L M112G V112 HS V212 HS M112 HS M112S M212 HD M212D M212 RA M212 RAD M212A M112 GRA M112 GRAD M112 GA RE112 RE212 M212 LRV BS312 US21

1Pack 10 Pieces セパレートロングシャフトゴム砥石 Separate Long Shaft Abrasive Rubber Points Screw M1.7

10,000 r.p.m. 8,000 r.p.m.

Hardness: ミディアムタイプ Medium Touch 砥粒 WA

Applicable Materials: アルミニウム Aluminium, 合金工具鋼 Alloy tool steel, ステンレス鋼 Stainless steel

| | | | |
|------|---------|---------|---------|
| #80 | DB 3701 | DB 3711 | DB 3731 |
| #120 | DB 3702 | DB 3712 | DB 3732 |
| #180 | DB 3703 | DB 3713 | DB 3733 |
| #220 | DB 3704 | DB 3714 | DB 3734 |

1Pack 1 Piece 専用シャフト Shaft for Separate Abrasive Rubber Points Shank ϕ 3.0

ϕ 3.0 L 50.0mm L 60.0mm L 70.0mm L 80.0mm

★DB 3794

1Pack 10 Pieces ロングシャフトゴム砥石 Long Shaft Abrasive Rubber Points Shank ϕ 3.0

10,000 r.p.m. 6,000 r.p.m. 5,000 r.p.m. 4,500 r.p.m.

#180

Hardness: ミディアムタイプ Medium Touch 砥粒 WA

Applicable Materials: アルミニウム Aluminium, 合金工具鋼 Alloy tool steel, ステンレス鋼 Stainless steel

| | | | | |
|------|---------|---------|---------|---------|
| #180 | DB 3811 | DB 3812 | DB 3813 | DB 3814 |
| #320 | DB 3821 | DB 3822 | DB 3823 | DB 3824 |

NEW



オーバーハング55mm以内、また表示してある最高回転数以下の条件でプレがないことを確認のうえ、ご使用ください。
Please use the long shaft abrasive rubber points under conditions that overhanging is within 55mm and maximum rotation speed is less than indicated one on catalog.

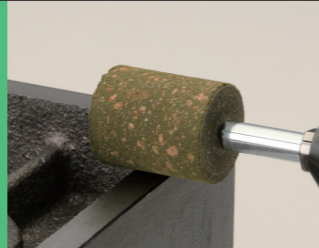

特徴 Features

- 研削作業に適したゴム砥石です。
Suitable for grinding.
- 弾性効果により、スクラッチが入りにくく、均一な研削面が得られます。
Providing uniform finishing without much scratching by elastic effect.

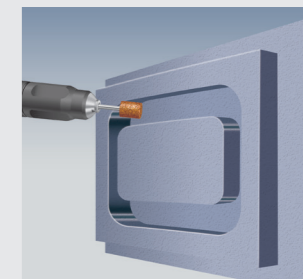

| | | | | | | | |
|-------------------------------------|--------------------------------|---|--------------------------------|-------------------------------------|---------------------------|--|-----------------------------------|
| 適合素材 Applicable Materials | セラミックス・ガラス Ceramics / Glass | 工具鋼・合金鋼 Tool Steel / Alloy Steel | 樹脂・ゴム Resin / Rubber | 適合機器類 Applicable Machines | エアークラインダー Air Grinder | ボール盤・電気ドリル Drill Press / Electric Drill | スピンドル Machine Tools Attachment |
| | 超硬合金・サーメット Carbide / Cermet | 一般鋼・ステンレス General Steels / Stainless Steel | アルミニウム・銅 Aluminium / Copper | | 両頭グラインダー Bench Grinder | ハンド Hand Use | 自動機ロボット Automatic Machines |

MINIMO推奨ハンドピース Recommended MINIMO Handpieces

● 最適 Most Suitable ● 使用可能 Suitable

V112H V212H M112H M212H V212 M112 M212 M212L M112G V112 HS V212 HS M112 HS M112S M212 HD M212D M212 RA M212 RAD M212A M112 GRA M112 GRAD M112 GA RE112 RE212 M212 LRV BS312 US21

1 Pack
5 Pieces Shank ϕ 6.0



| | | | | |
|------|---------|---------|---------|---------|
| #80 | DB 4401 | DB 4411 | DB 4421 | DB 4431 |
| #120 | DB 4402 | DB 4412 | DB 4422 | DB 4432 |
| #220 | DB 4403 | DB 4413 | DB 4423 | DB 4433 |
| #320 | DB 4404 | DB 4414 | DB 4424 | DB 4434 |